

YOUR ADVENTURE UNFOLDS

# Kahuna

*Feathercraft*  
FOLDING KAYAKS <sup>TM</sup>

Feathercraft Products Ltd. 4-1244 Cartwright Street on Granville Island, Vancouver, British Columbia, Canada V6H 3R8  
Telephone: (604) 681-8437 Fax: (604) 681-7282 [www.feathercraft.com](http://www.feathercraft.com) [info@feathercraft.com](mailto:info@feathercraft.com)

# Contents

Kahuna Folding Kayak.....	Page 2
Specifications .....	Page 3
Kahuna Frame .....	Page 4
Care and Maintenance .....	Page 5
Disassembly .....	Page 6
Kahuna Assembly Instructions .....	Page 8
The Feathercraft Sea Sock.....	Page 21
Optional Rudder Installation .....	Page 22
Optional Hatch Installation .....	Page 26

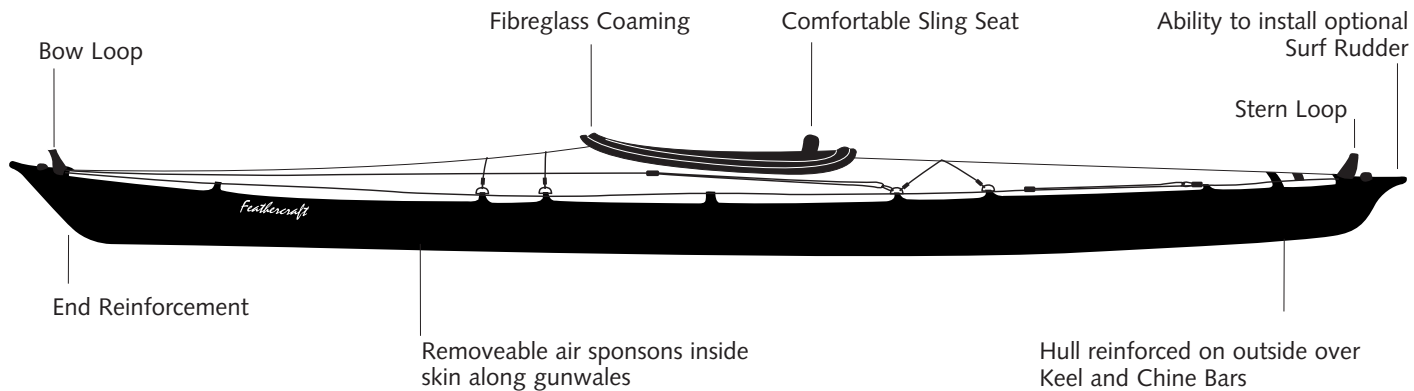

## The Kahuna Single Folding Kayak

# Specifications

Length: 4.5 m (14'9")  
Beam: 64 cm (25")  
Weight: 16 kg (35 lbs)  
Pack size: 90 x 50 x 25 cm (36 x 20 x 10")  
Storage Volume: Medium  
Frame: 5/8" Round  
6063 - T832 Extruded Aluminum  
Magnesium Tubing with clear  
Anodized Coating  
Crossribs: Injected Molded Polycarbonate  
Deck Material: Polytech  
Hull Material: Duratek

## Accessories:

Included in every kayak:

Nylon Spray Skirt  
Sea Sock  
Adjustable Foot Braces/Rudder Controls  
Repair Kit  
Pack Bag  
Assembly Video  
Illustrated Instructions

## Options:

Access hatches  
Surf rudder

# Kahuna Frame

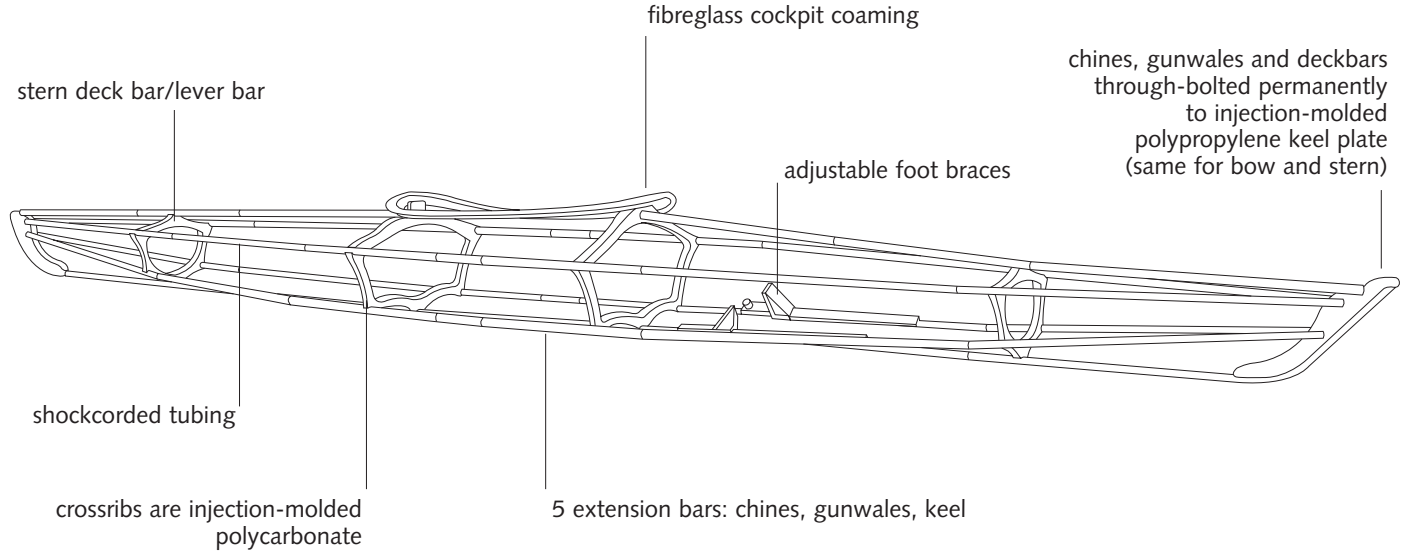

# Care and Maintenance

## The Frame.

The tubular frame is very strong and corrosion resistant. We recommend that the frame be disassembled after extensive use (2 – 3 months). The inside and outside of the tubes should be washed with fresh water. Try to keep the inserts and extension bars free of sand and grit.

Included in your repair kit is a small dropper tube of Bo-Shield T-9. This product is made by Boeing and is an excellent lubricant and protectant for aluminum.

Aerosol containers of Bo-Shield can be found at marine hardware stores. We also have available 4 oz bottles of Bo-Shield. However, please note, that the lid closure is not suitable for shipping after the bottle has been opened. This container would be good for your “at home” clean-up. We also have available Super Lube. This is a teflon lubricant in gel form. This product is also available from bike shops.

Apply the Bo-Shield lubricant to frame tube inserts, spring buttons and sliding pieces prior to assembly. If you should leave your boat assembled for a maximum of two months, this will assist in preventing tubes seizing.

Other maintenance “musts”:

- every two months completely disassemble the kayak.
- wash the frame completely with fresh water.
- reapply lubricant and/or wipe down tubes with Bo-Shield T-9.
- after paddling, sponge out the inside of the kayak. Do not allow water to pool along keel bar.

## The Skin

The surfaces of the skin will not rot. They are stable in sunlight and are very tear-resistant. On the hull, areas likely to be exposed to abrasion have been reinforced. However, we recommend care when approaching shore. Sharp rocks, and barnacles can penetrate the skin. Never haul the boat over rocks.

For patching and repairs, a patch kit is included. For quick field repair, duct tape works very well, and is a good addition to your repair kit.

## Welded Sealskin.

The Polytech deck and Duratek hull are urethane. Seams are permanently sealed.

A patch kit is provided for deck, hull or sponson punctures. One urethane glue will work for repairs to all of these fabrics. Glue does have a shelf life and it should be fluid and not thick and gummy. We have replacement cans available.

## Sponsons

Due to the tight fit of the skin, the sponsons are under considerable pressure and some seepage of air may occur. It is advisable to periodically reinflate the sponsons. After paddling on hot days, release air from sponsons.

## To Repair/Replace Sponson

The sponsons can be completely removed from the sleeve sewn to the inside of the skin. Turn the skin inside out. The sponson chamber is open at bow and stern ends. Tie a long string through the hole in the tab at the end of sponson. Pull sponson through the center opening of the chamber (where sponson hose is attached). To reinstall, pull the cord attached to the new sponson back through the chamber. Ensure sponson is not twisted in the chamber. Repeat with the opposite side. Urethane glue and patches are included in the repair kit. Duct tape works well on the sponsons.

# Disassembly

Let the air out of the sponsons. Remove Cockpit Coaming. Remove deck bars. Remove Gunwale and Chine Extension bars using the lever bars to release the spring buttons. Release the Keel Extension Bar last. Follow the rest of the assembly steps in reverse order.

## Packing the kayak in the bag

Put the seat cushion in the bag first, with the cushion facing down, to give padding for your back. Next arrange the white plastic crossribs over the seat. Stretch the sprayskirt over the fiberglass coaming. Place this in the bag, over the crossribs. Roll the kayak skin up tightly—fold the ends to the center of the kayak; fold in half; roll tightly; secure with webbing ties. Place this bundle in one side of the bag. Put aluminum frame parts along side of the rolled up skin. Tuck all additional pieces (ie: sea sock, repair kit) into any available space.

## Lifting the Kayak

The webbing handles at the bow and stern ends can be used to lift or carry. **Never lift or carry a fully loaded kayak.**

## Storage

Once clean and dry, the kayak can be stored assembled or disassembled in a shaded, dry place. When storing the kayak disassembled, take extension bars apart.



# Kahuna Assembly Instructions

Stern Crossrib—marked with "S"

Seat

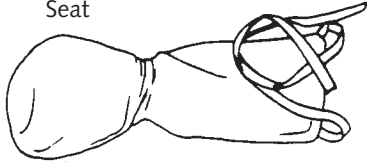

One-piece fibreglass coaming

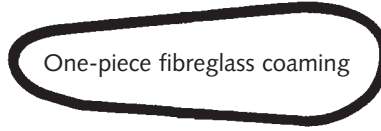

Skin



Seat Sling

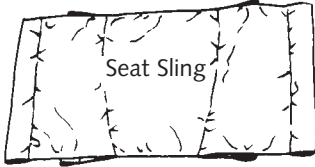

Crossribs

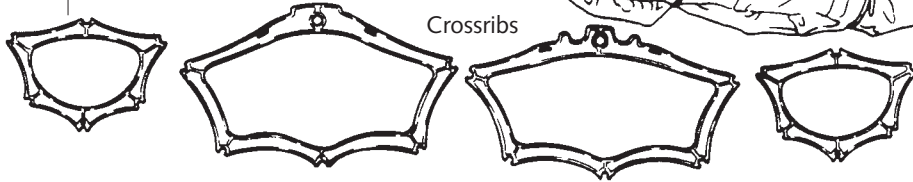

Bow deck bar is slightly bent

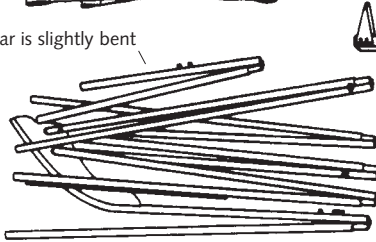

Bow Section

Bow Deck Bar/Horizontal Lever

Stern Deck Bar/Horizontal Lever



Keel Extension Bar (has double band of black tape at stern)



Chine and Gunwale Extension Bars

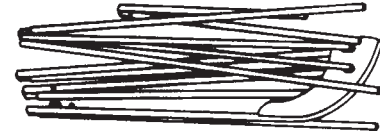

- 1 SET OUT FRAME PARTS AS ILLUSTRATED ON THE PREVIOUS PAGE
  - 2 BOW SECTION  
(has foot track installed on chine bars).
- “Shake out” bow section. Shock corded tubes take shape.

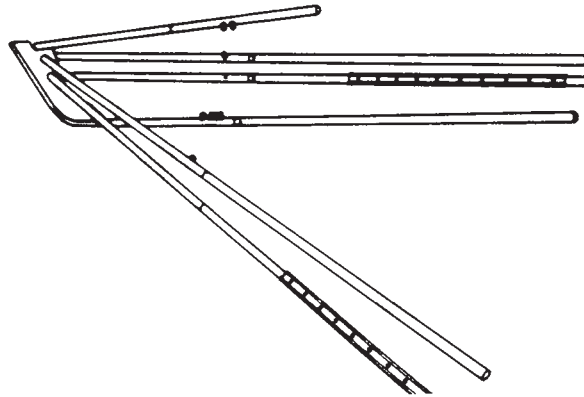
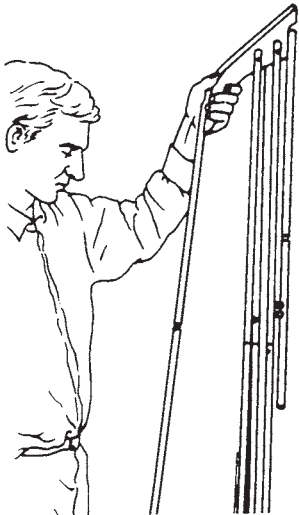

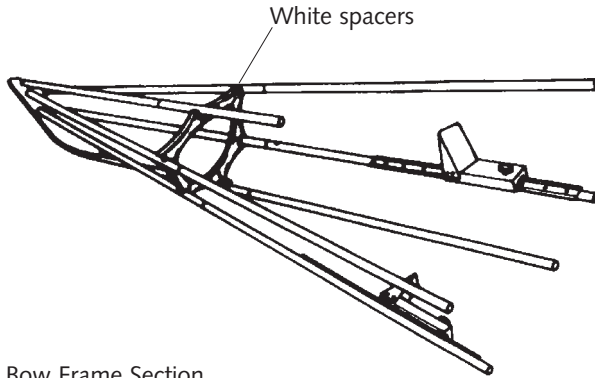
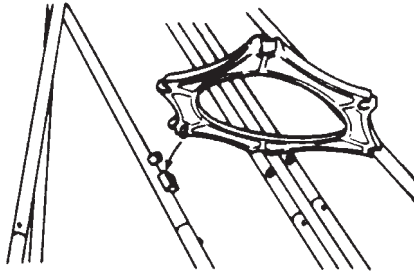

Bow Frame Section

**3 ATTACH SMALL CROSSRIB TO BOW SECTION.**

- Pin on small crossrib is inserted into hole in plastic block on keel tube; fit into place.
- Snap chine and gunwale tubes on to crossrib. When the crossrib is in position, the white spacers are on the "cockpit" side of the crossrib.

**4 COMPLETE BOW SECTION.**

- Slide foot braces on to track. If necessary, the foot plate on the brace can be reversed.

**5 STERN SECTION.**

- Repeat Step #2 and #3.

**6 UNFOLD SKIN.**

- There are two Velcro-tab closures on the inside of the hull. These are located through the main cockpit opening, bow and stern.

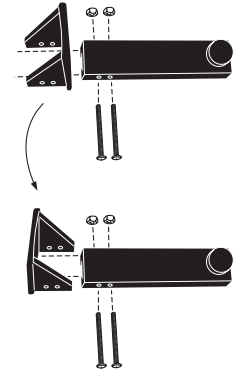

Stern Frame Section

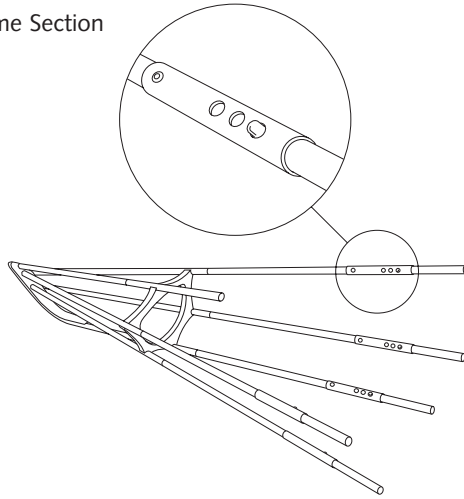

Variations do occur with the fabric skin. For this reason, the stern frame section has adjustable members. The initial set-up of the kayak has the spring button in the hole closest to the cockpit.

In Step 12, as you are extending the frame, if the skin feels too tight, the frame can be shortened to accommodate the fit. Have all adjustments on the same setting, with the spring buttons facing away from the hull.

#### 7 INSERTING FRAME SECTIONS TO SKIN.

- Before inserting the frame into the skin, ensure the velcro tabs are open. Slide the bow and stern frame sections into the skin. (Feathercraft label is on the bow end.)
- When inserting the frame sections, align and centre the frame using the tabs as guides. Snug the frame sections to the very tip of the skin. Secure Velcro closure around the keel bar.

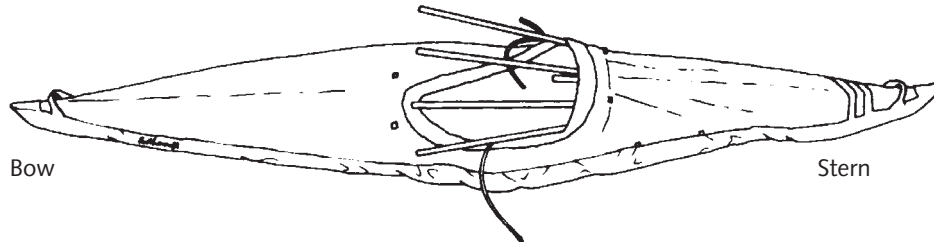

8 INSTALL KEEL EXTENSION BAR.

- Keel extension bar has two bands of black tape on the stern end, and one band of black tape on the bow end.
- Slide the stern end of the extension bar on to the stern keel bar. Slide the bar apart, attaching the other end to the bow keel bar.

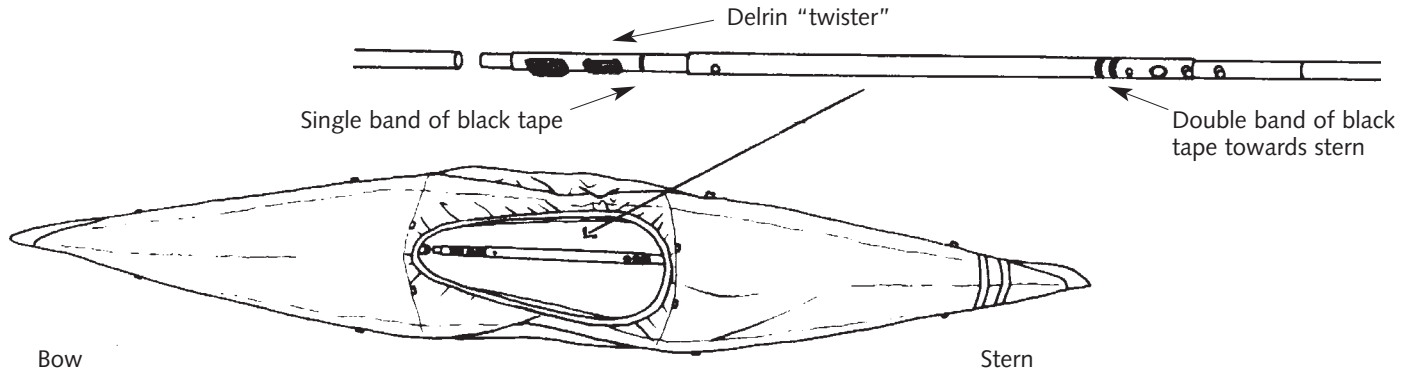

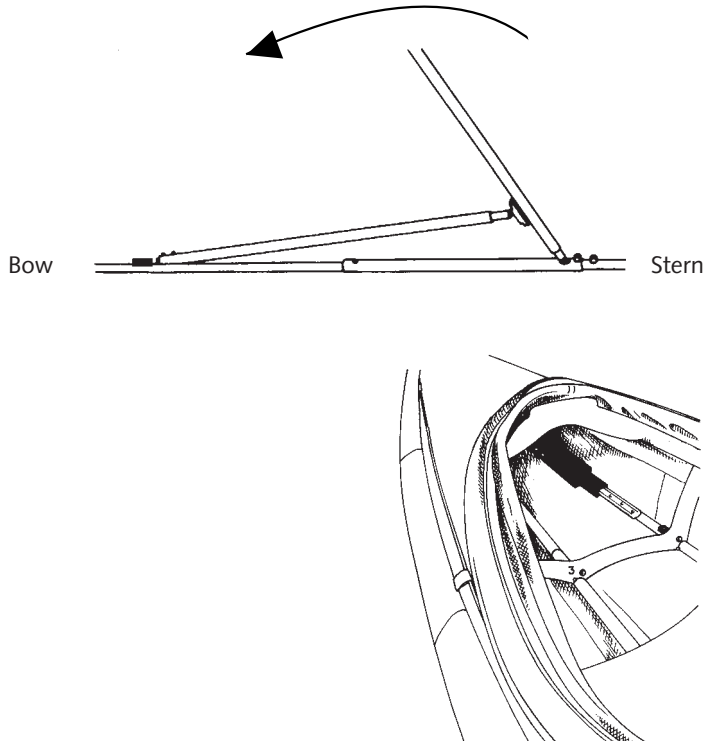

#### 9 EXPAND KEEL EXTENSION BAR.

- Lever keel extension using Stern Deck Bar/Vertical Lever and Bow Deck Bar/Horizontal Lever. Expand until spring pops up.

#### 10 INSTALLING FIBREGLASS COAMING.

- Place fibreglass coaming over cockpit opening. A thin piece of rubber is sewn into the skin around the cockpit opening. This edge is brought through the cockpit opening, and tucked into the groove in the fibreglass coaming. (It is a snug fit.)
- Start with inserting a portion at the bow. Then insert a portion at the stern. Complete with inserting the sides.
- Note: if the deck has become tight, the coaming can also be installed after the bow crossrib is in place.

#### Note to Step 9:

Due to the nature of the skin fabrication, there can be minor "fit" differences from one boat to another. We have made three positions for the keel bar extension to allow for these differences in expanding the frame to the skin. Expand the keel bar to the hole that feels tight. (Usually, this will be the middle hole.)

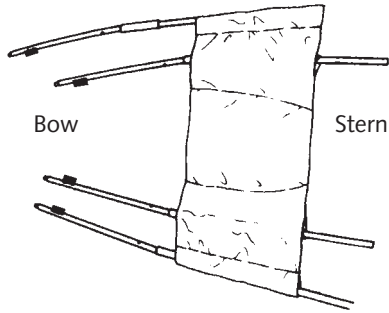

11 INSTALL SEAT SLING.

- The seat sling will be suspended from the chine and gunwale extension bars. These extension bars are all the same. Stern end of seat sling has narrower stitching. While installing and expanding these extension bars, you may wish to slide the seat sling over the chine and gunwale bars on the stern section of the frame. Otherwise, slide Extension Bars through loops in sling with the black delrin blocks oriented towards the bow.

**Note: When installing frame parts in the kayak, it is easier to be situated on the opposite side from the part you are installing.**

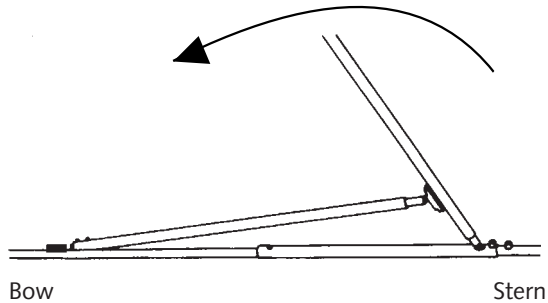

12

- Install chine and gunwale extension bars.
- Once the bow and stern frame sections have been inserted to the skin, they begin to take the curved shape of the kayak. It will be easier to slide tubes together when the tubes are in a straight line to each other.
- The black Delrin block on the extension bars points to the bow. Slide the bars open, and join to the bow and stern sections.
- Expand the chine bars as you did the keel bar, till the spring button appears in the first hole.
- Expand the gunwale bars to the first hole.
- Go back, and expand the keel to the second hole.
- Expand chine and gunwales to the second hole.
- Slide the seat sling forward for seat positioning.



Note: This step is done when frame is in the skin.  
For illustration purposes, we have shown it without the skin.

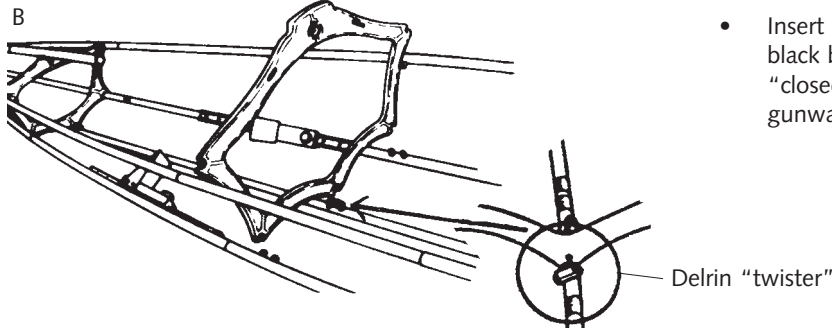
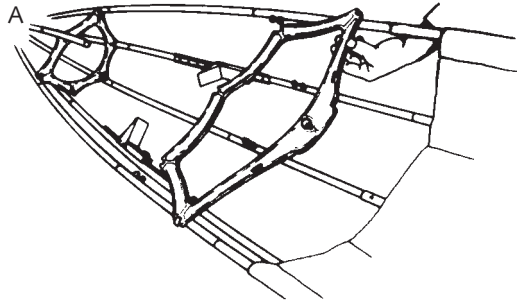

### 13 INSTALLING LARGE CROSSRIBS.

- Position large crossrib to lay on top of gunwale tubes. Slide forward towards pins on gunwale tubes. Rotate crossrib into position.
- Place crossrib between gunwale pins nearest you by pushing gunwale bar up over end of crosspiece and snapping into position.

#### FOR BOW CROSSRIB:

- There are two black plastic blocks mounted on the keel bar. One is mounted with a screw and can be rotated. When rotated away from the other block, it is in the "open" position. Have the block set in the "open" position.
- Insert pin located on bottom of crossrib into stationary black block on keel bar. Twist the second block into the "closed" position. Snap crosspiece into position on gunwales, then chines.

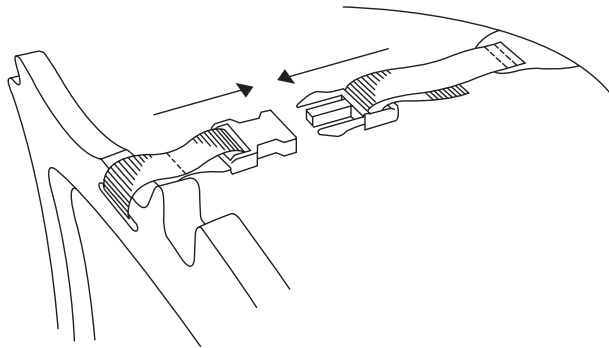

**14 REPEAT STEP 13 FOR INSTALLATION OF STERN CROSSRIB.**

- Procedure is the same, except for twister.

**ALTERNATE SEQUENCE TO INSTALLING EXTENSION BARS & CROSSRIBS.**

- Slide the keel extension bar into place. Using the lever bars, extend to the first hole.
- Install chine and gunwale bars with seat sling. Connect to the bow and stern sections, but do not use lever bars to extend yet.
- Install large bow and stern crossribs as described, snapping the tubes onto crossribs.
- Now, return to the chine and gunwale extension bars. Use the lever bars to extend each of the four bars to the second hole. Extend both extension bars on one side, then the other.
- Extend the keel bar to the second hole.

**15. SECURE DECK-WEBBING TO CROSSRIB.**

- Attached to the underside of the deck, behind the large crossribs, are pieces of webbing with buckles.
- Clip to the corresponding buckle attached to the crossribs. Same for bow and stern large crossribs.

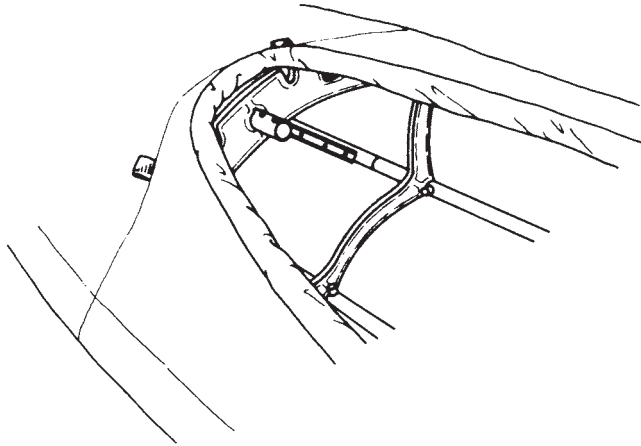

**16 INSTALL BOW DECK BAR.**

- Insert through small hole in top of large crossrib.
- Join to shockcording deck bar.
- Hold through deck.
- Turn to lock into place.

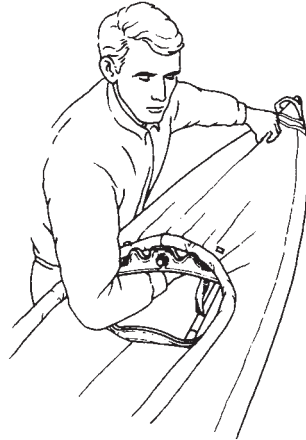
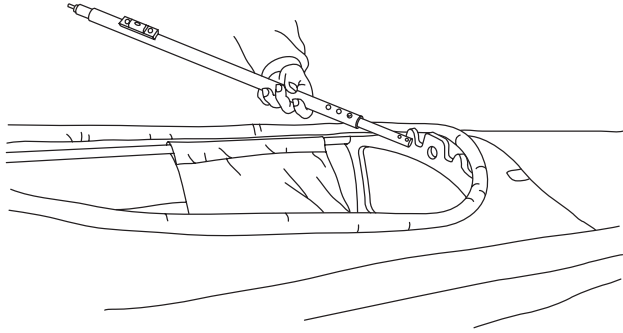

#### 17 INSTALL STERN DECK BAR.

- The stern deck bar has the same spring-button adjustments as the stern frame section. Have the spring button position on the deck bar at the same position as the rest of the stern section.
- Put the stern deck bar through the center of the large crossrib: end with black block pointing towards the stern.
- Bring deck bar end closest to you, back through small hole in top of crossrib.
- Line up bar, and insert to shockcorded deck bar. Hold the shockcorded deck bar through the deck while turning the deck bar to lock into place (as you did in Step #15).
- Ensure spacers on the deck bar do not face upward, pushing against inside of the deck.

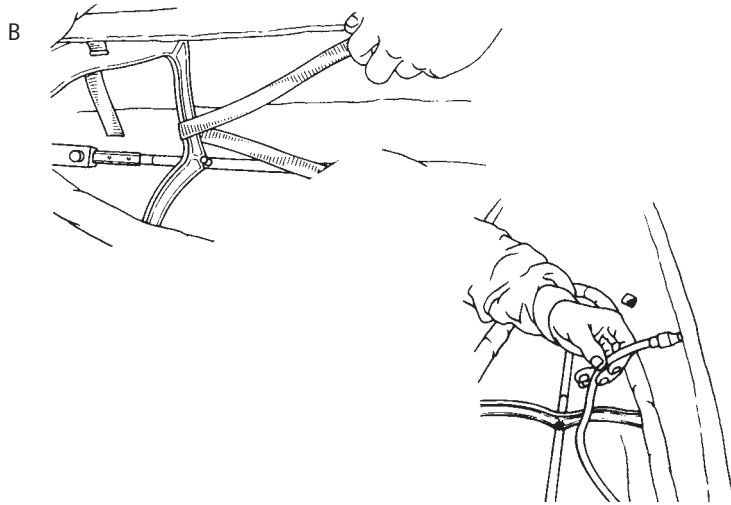
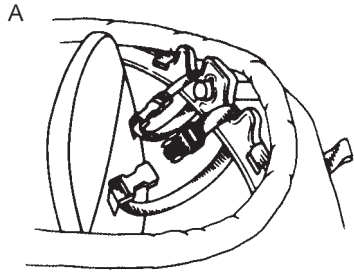

**18 INSTALLING SEAT.**

- Webbing at top of seat goes through crossrib, over top, connecting to buckle.
- Webbing at front of seat reaches the large crossrib and attaches around the side of the crossrib. Connect to ladderlock to fasten.
- Note: Webbing goes above chine bar.

**19 INFLATE SPONSONS.**

- Turn the top of the valve to open. When inflating sponsons, alternate sides to ensure the frame remains centered. The air pressure from the sponsons can shift the frame within the skin. Keep blowing until the skin is nice and tight. Twist top cap to close. Tuck sponson tubes and valves out of the cockpit area. Avoid stepping on the hose and valve, and try to keep the valve free of sand.

## The Feathercraft Sea Sock

Made from high-quality coated nylon, the sea sock is a great safety item. The top of the sock fits tightly around the cockpit coaming rim. Contoured to fit along the seatback and bottom, the “foot” is loose through the cockpit, creating a “pod”. The paddler then sits in the sock. Legs and feet are not constricted. The spray skirt fits as usual. In the event of a capsize, water will only enter the sock, and not the whole boat. It's also great for keeping the inside of your kayak clean.

As an optional upgrade, the Sea Sock can be ordered with a neoprene rim-grip. This gives an extra tight fit for paddling in extreme weather conditions.

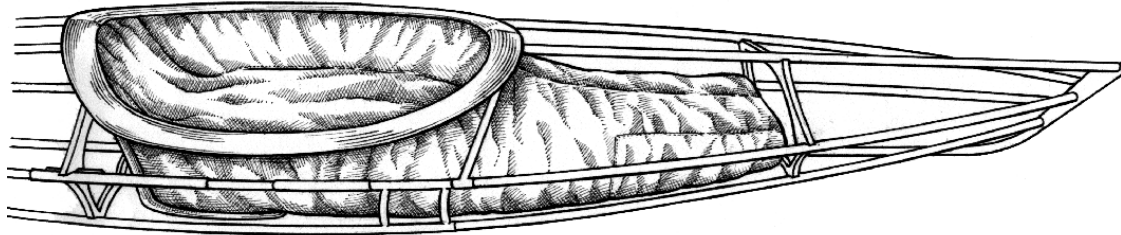

## Tips on Usage and Installation

- The shiny side of the fabric faces in towards the kayak frame.
- When facing the bow of the kayak, the Feathercraft label should be on the right side.
- The center seam on the up-side of the Sea Sock should be centered on the bow point of the coaming.
- Once the Sea Sock is in place, sit in the sock, and “burp” it by lifting the edges, releasing trapped air that causes the sock to billow up.

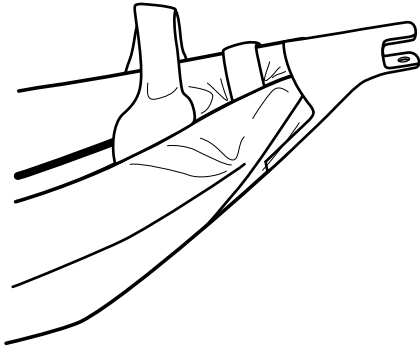

## Installation of Optional Accessories

### TO INSTALL THE OPTIONAL SURF RUDDER

The rudder casting is permanently attached to the stern of the kayak.

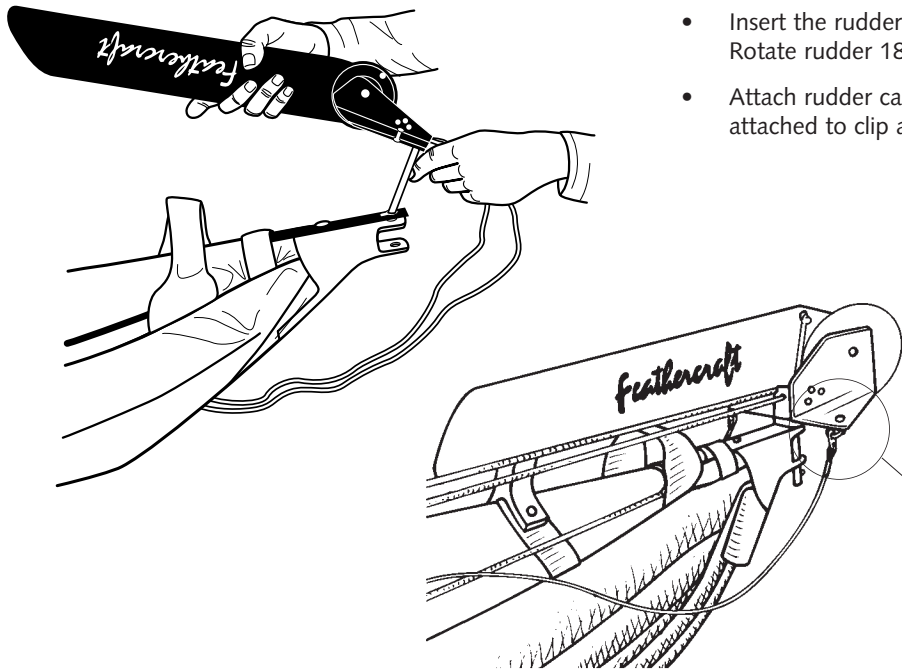

**INSTALL RUDDER.**

- Insert the rudder pin through the “key hole”. Rotate rudder 180°.
- Attach rudder cables with sister clips. White haulcord is attached to clip at the side of the cockpit.

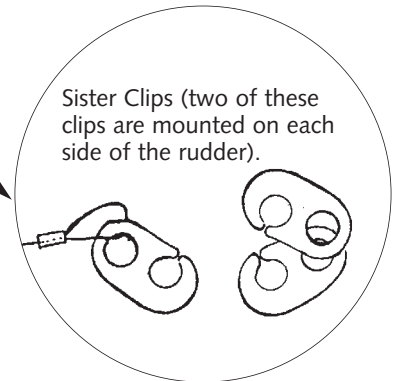



**A CONNECTING RUDDER CONTROL TO FOOT BRACE**

- Red webbing adjusters are connected to the foot brace. Unscrew thumb-knob on foot brace; stem of knob goes through grommet. To make the adjuster shorter, fold webbing over to second grommet. Re-attach knob to foot brace. Slide brace on to track. Ensure brace can slide easily on track. (If not, check knob that you re-attached.)

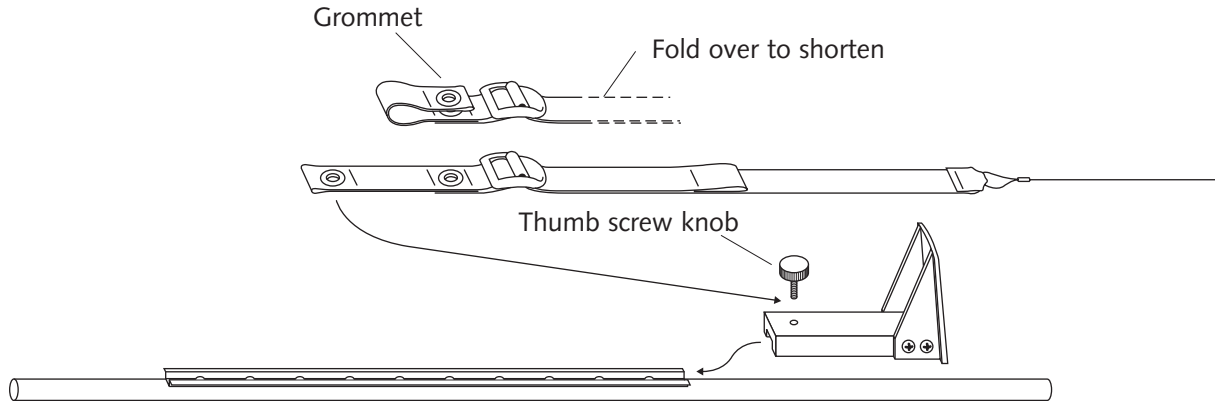

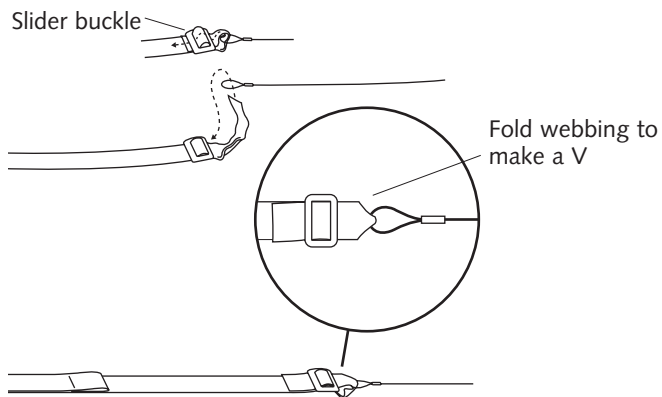

**B CONNECT CABLE ADJUSTER TO STAINLESS STEEL CABLE.**

- This is to attach the adjuster if you have installed the rudder from a kit.
- Slide end of webbing through slider buckle. Thread the webbing through the loop in the stainless steel rudder cable. Fold or “pinch” webbing to make a V. Re-thread webbing through slider buckle.

**C CABLE LENGTH ADJUSTMENT**

- To shorten cable length, pull on tab of webbing with loop; to lengthen, lift tab of ladder-lock buckle.

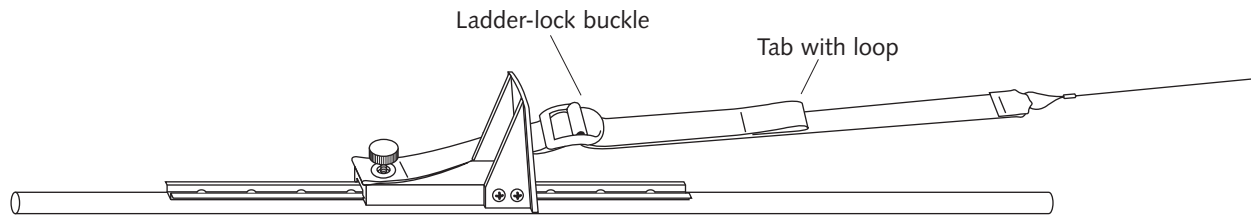

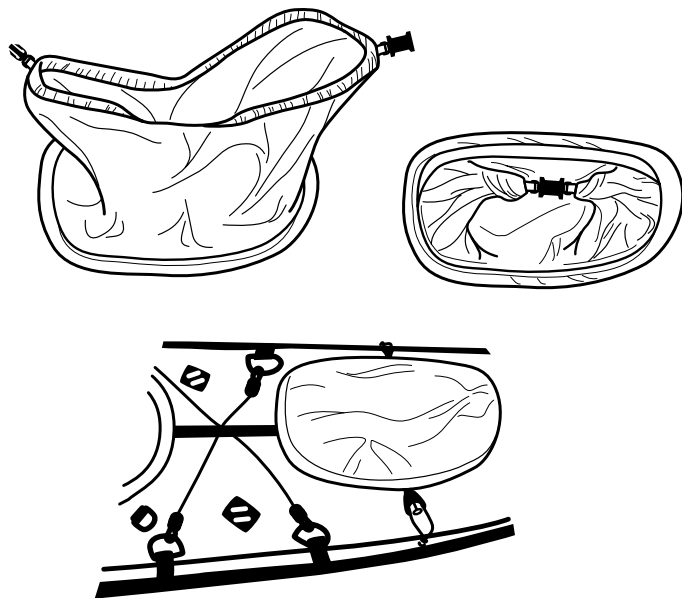

## To install optional hatches

### ATTACH HATCH RIMS.

- Attach hatch rims by folding the fabric sleeves sewn to the deck over the rim. Roll down inner closure and close with buckels. Place hatch cover over rim and secure with B-locks.
- During disassembly, don't forget to take the plastic rims off. Don't roll the skin up with the rims still in place.

© Feathercraft Products Limited 2001  
Printed in Canada 05.2001  
Recycled paper





